

## waterline SA300 SC

BRACCIO DOCCIA IN&OUT, CON GETTO A CASCATA E SOFFIONE INTEGRATO 220X110 MM  
 SHOWER ARM IN&OUT, WITH CASCADE SHOWER AND 220X110 MM CONCEALED SHOWERHEAD  
 BRAS DE DOUCHE IN&OUT, AVEC POMME DE DOUCHE CASCADE ET POMME DE DOUCHE INTEGRÉE 220X110 MM  
 BRAZO DE DUCHA IN&OUT, CON DUCHA DE CASCADA Y ROCIADOR INTEGRADO 220X110 MM  
 WANDBRAUSE IN&OUT, MIT WASSERFALL UND 220X110 MM INTEGRIERTER KOPFBRAUSE

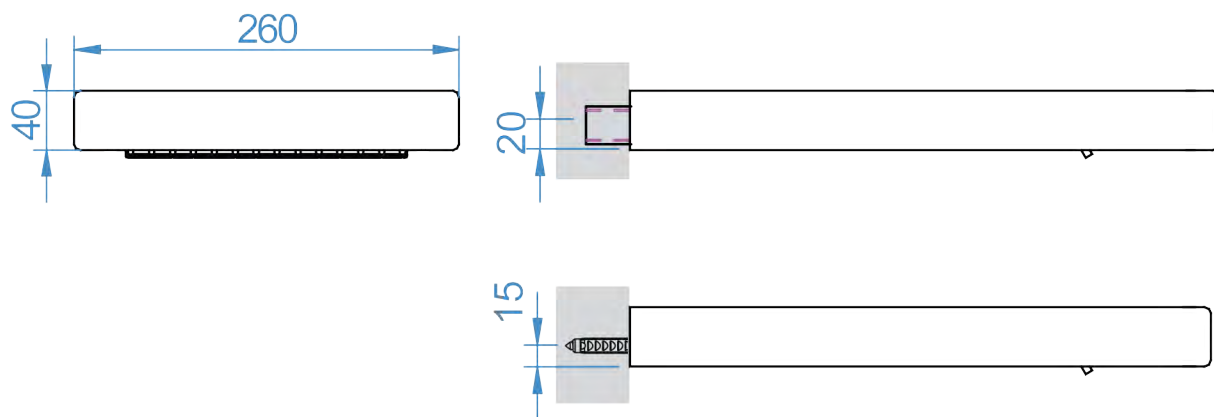

INDICAZIONI PER L'INSTALLAZIONE  
 INDICATIONS FOR INSTALLATION  
 INDICATIONNE POUR L'INSTALLATION  
 INSTALLATIONSANWEISUGEN  
 INDICACIONES PARA LA INSTALACIÓN

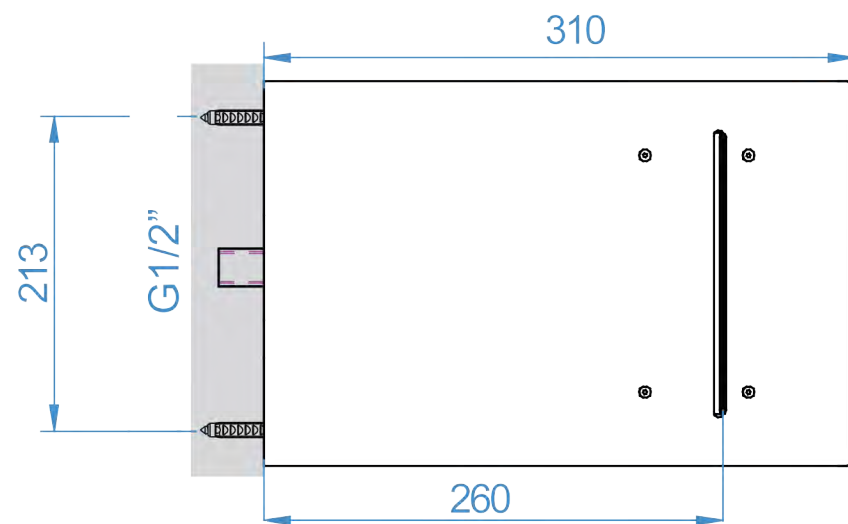
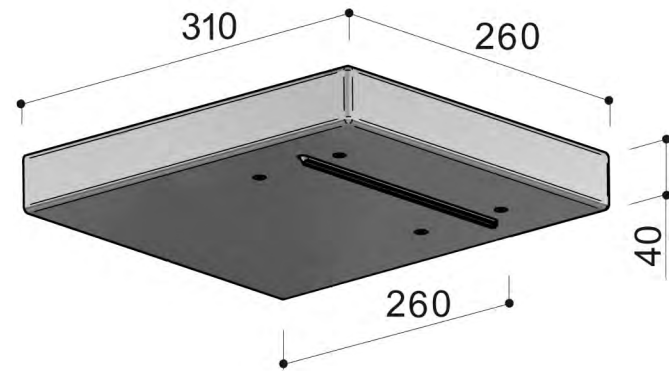
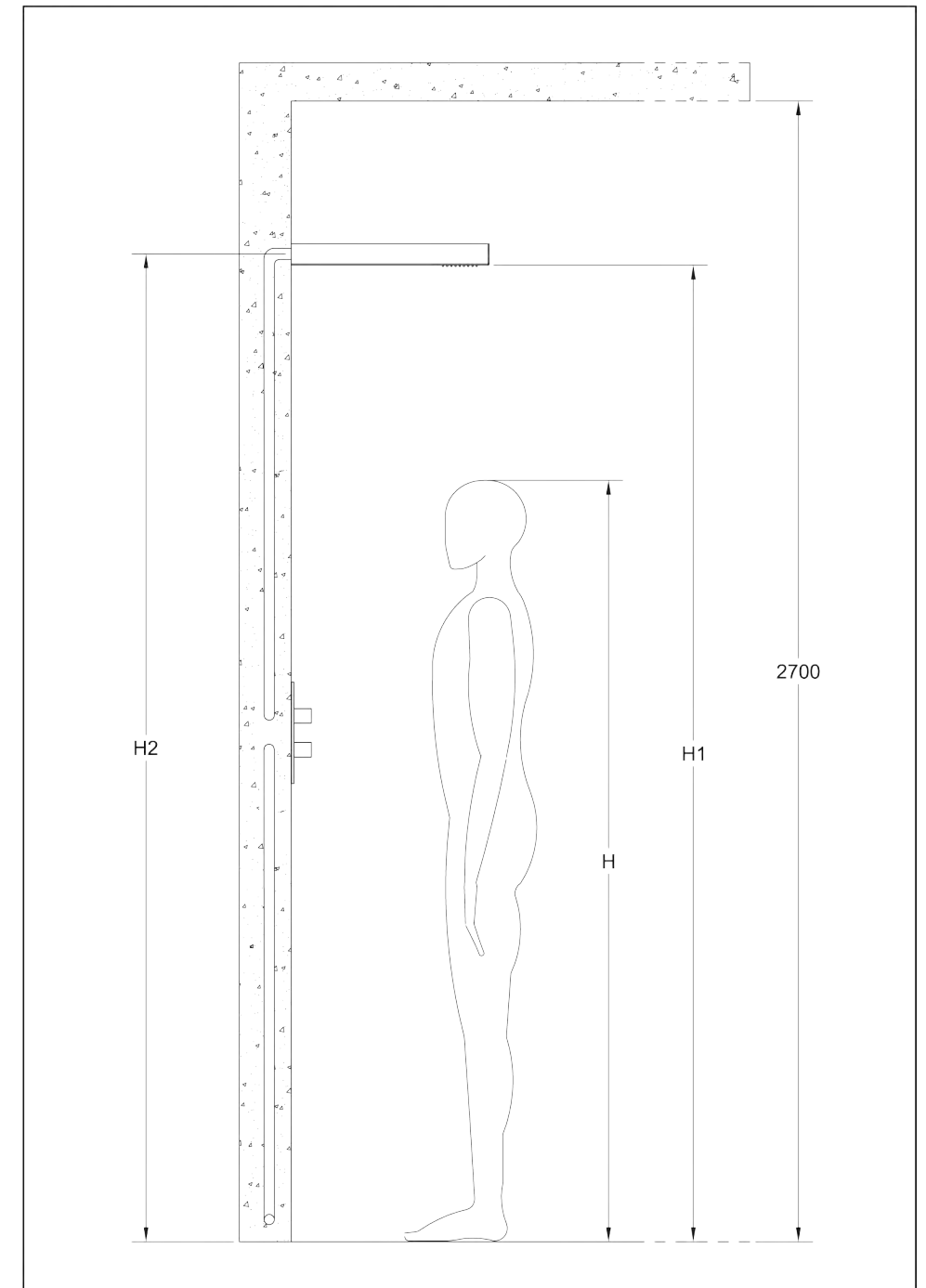

H [mm]	H1 [mm]	H2 [mm]	H3 [mm]
1600	2100 ÷ 2200	H1 + 25	H1 + 30
1700	2100 ÷ 2200		
1800	2200 ÷ 2300		
1900	2300 ÷ 2400		

H = Statura cliente - Customer height - Hauteur client - Größe des Kunden - Altura cliente

H1 = Altezza consigliata - Recommended height - Hauteur conseillée - Empfohlene Höhe - Altura aconsejada

H2 = Altezza presa acqua - Water inlet height - Hauteur prise eau - Höhe des Wasserauslaufs - Altura toma de agua

H3 = Altezza foratura per fissaggio - Height of drilling for fastening - Hauteur perçage pour fixation - Höhe der Bohrungen für die Fixierung - Altura de horadación para la fijación